



# *Linea Española*

FASCINACIÓN POR LA ARQUITECTURA



**SERIE 10000**



# CORREDERA

## SERIE 10000

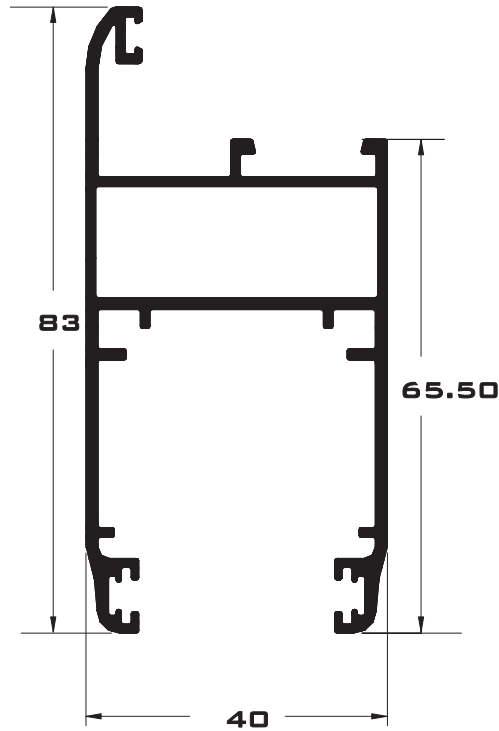

10001 HOJA PERIMETRAL CON JUNQUILLO

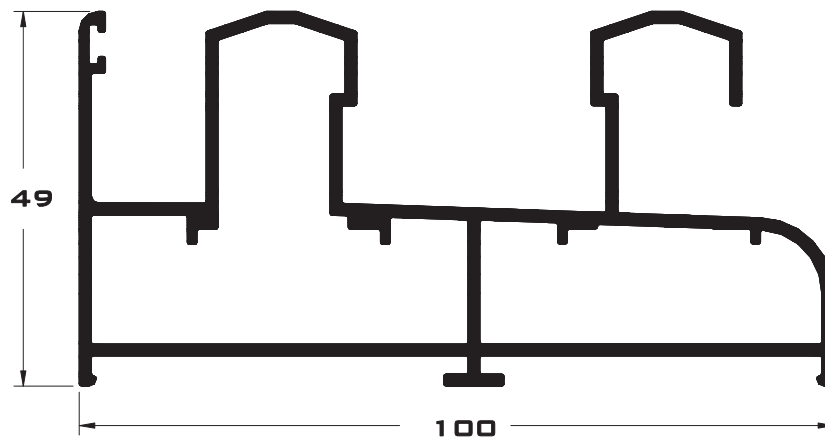

10002 CERCO PERIMETRAL

ESCALA 1:1

LONGITUD: 6.10 mts.



# CORREDERA

## SERIE 10000

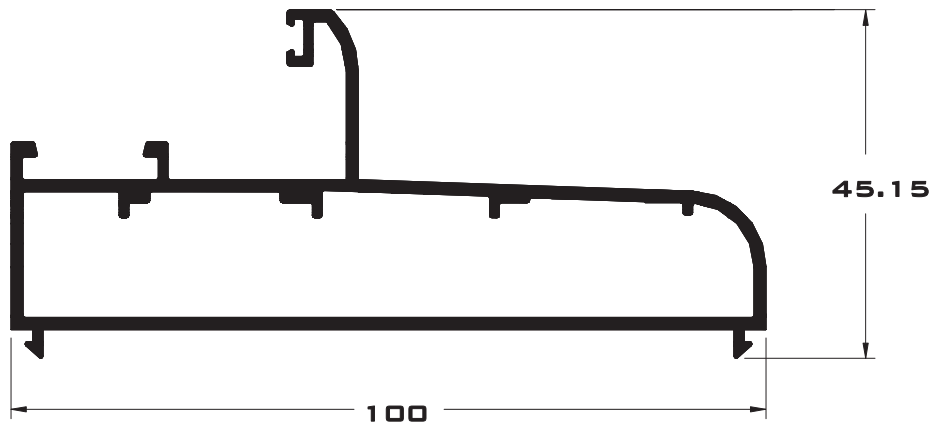

**10003 FIJO TUBULAR**

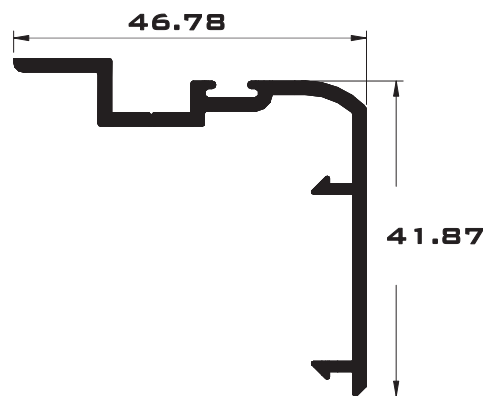

**10004 TAPETA HOJA CENTRAL**

**ESCALA 1:1**

**LONGITUD: 6.10 mts.**



# CORREDERA

## SERIE 10000

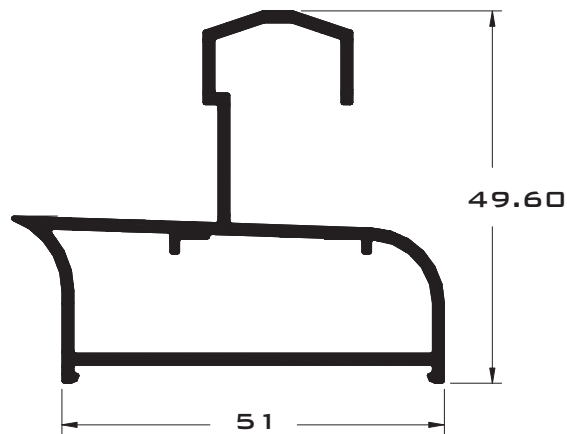

10005 ADAPTADOR 3 CARRILES PERIMETRAL

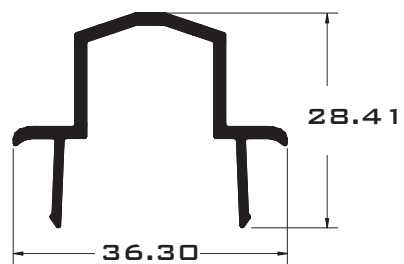

10006 UNION 4 HOJAS

ESCALA 1:1

LONGITUD: 6.10 mts.



# CORREDERA

## SERIE 10000

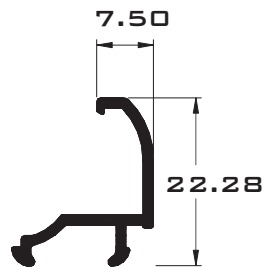

6027 JUNQUILLO HUECO 24MM.

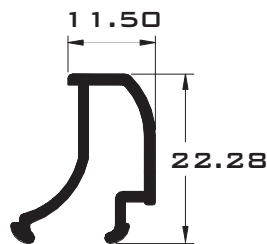

6028 JUNQUILLO HUECO 20MM.

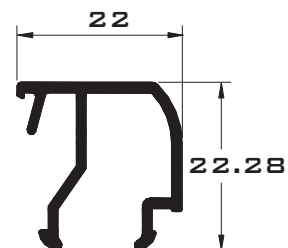

6029 JUNQUILLO HUECO 10MM.

ESCALA 1:1

LONGITUD: 6.10 mts.



# CORREDERA DOS HOJAS

## SERIE 10000

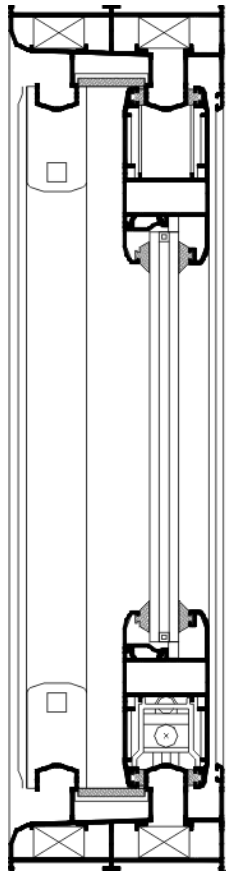

**A**

CORREDERA 2 HOJAS					
DESCRIPCION	CLAVE	CORTE	DIBUJO	CANTIDAD	MEDIDAS EN MM.
HOJA PERIMETRAL C/JUNQUILLO	10001	45°		4	A - 78
HOJA PERIMETRAL C/JUNQUILLO	10001	45°		4	B / 2
CERCO PERIMETRAL	10002	45°		2	A
CERCO PERIMETRAL	10002	45°		2	B
TAPETA HOJA CENTRAL	10004	90°		2	A - 82
CIERRE EMBUTIDO	7122		VER PAGINA HERRAJES	2	
CARRETILLA TANDEM	7124-0		VER PAGINA HERRAJES	4	
KIT PERIMETRAL	7123-7		VER PAGINA HERRAJES	1	
ESCUADRA HOJA	1325-0		VER PAGINA HERRAJES	8	
ESCUADRA CERCO	1324-0		VER PAGINA HERRAJES	8	
METROS FELPA	3204		VER PAGINA HERRAJES	S/MEDIDAS	

**B**

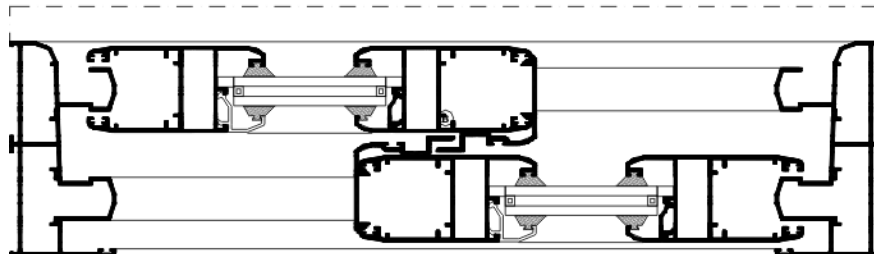



# CORREDERA TRES HOJAS

## SERIE 10000

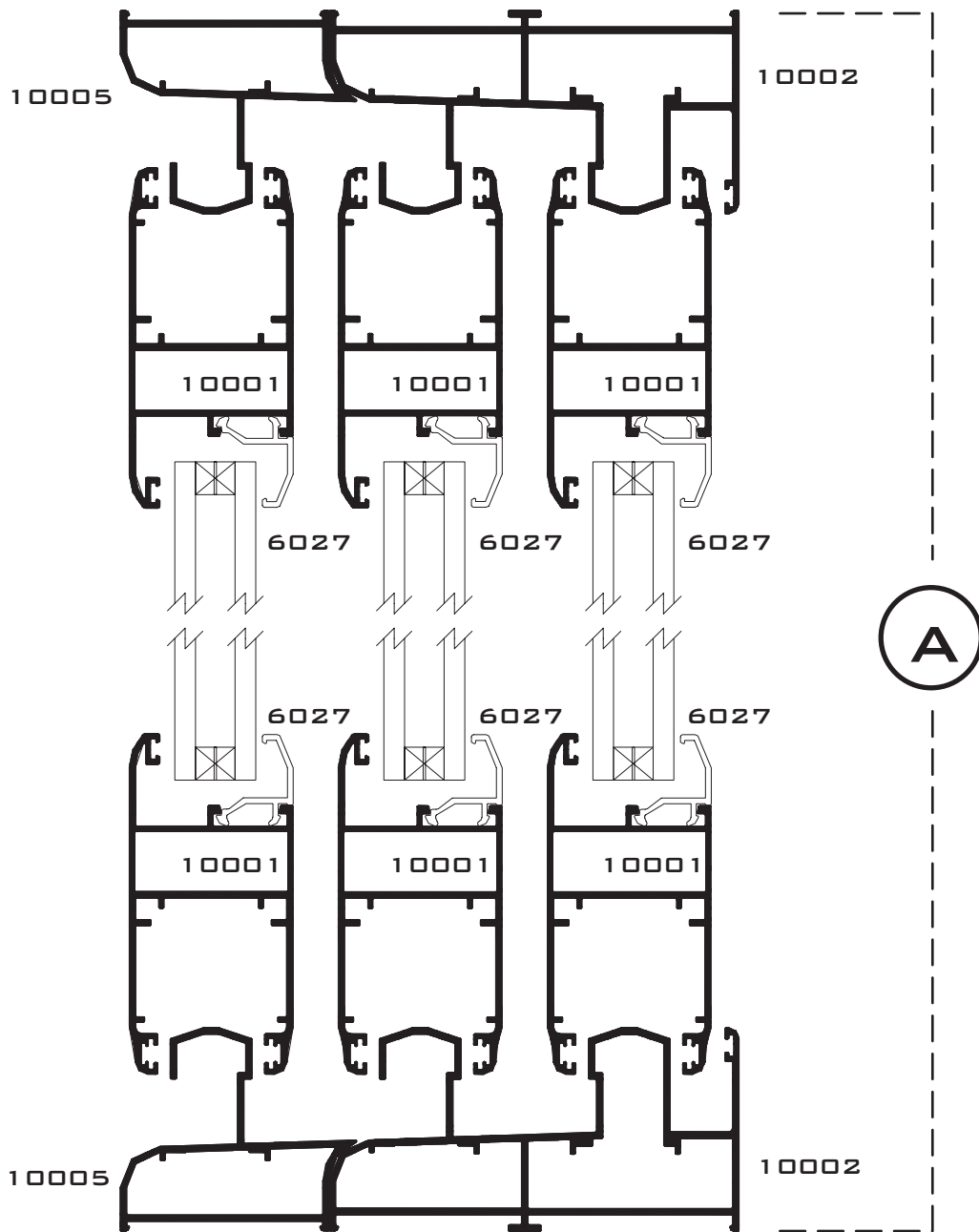







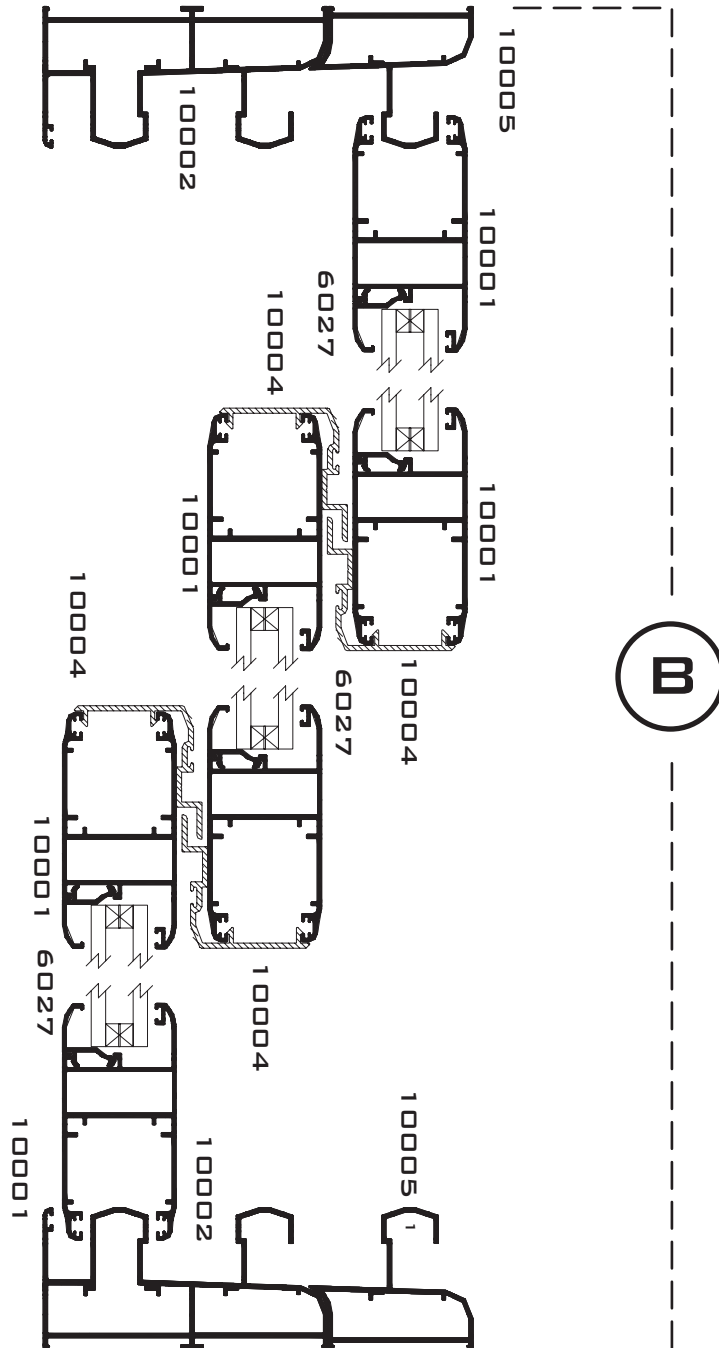

# CORREDERA TRES HOJAS

## SERIE 10000





CORREDERA 3 HOJAS 3 RIELES					
DESCRIPCION	CLAVE	CORTE	DIBUJO	CANTIDAD	MEDIDAS EN MM.
HOJA PERIMETRAL C/JUNQUILLO	10001	45°		6	A - 78
HOJA PERIMETRAL C/JUNQUILLO	10001	45°		6	B + 79 / 3
CERCO PERIMETRAL	10002	45°		2	A
CERCO PERIMETRAL	10002	45°		2	B
ADAPTADOR 3 CARRILES	10005	45°		2	A
ADAPTADOR 3 CARRILES	10005	45°		2	B
TAPETA HOJA CENTRAL	10004	90°		4	A - 82
CIERRE EMBUTIDO	7122			2	
CARRETILLA TANDEM	7124-0			6	
KIT PERIMETRAL	7123-7			2	
ESCUADRA HOJA	1325-0			12	
ESCUADRA CERCO	1324-0			12	
METROS FELPA	3204			S/MEDIDAS	



# GRAFICA DE RESISTENCIA AL VIENTO

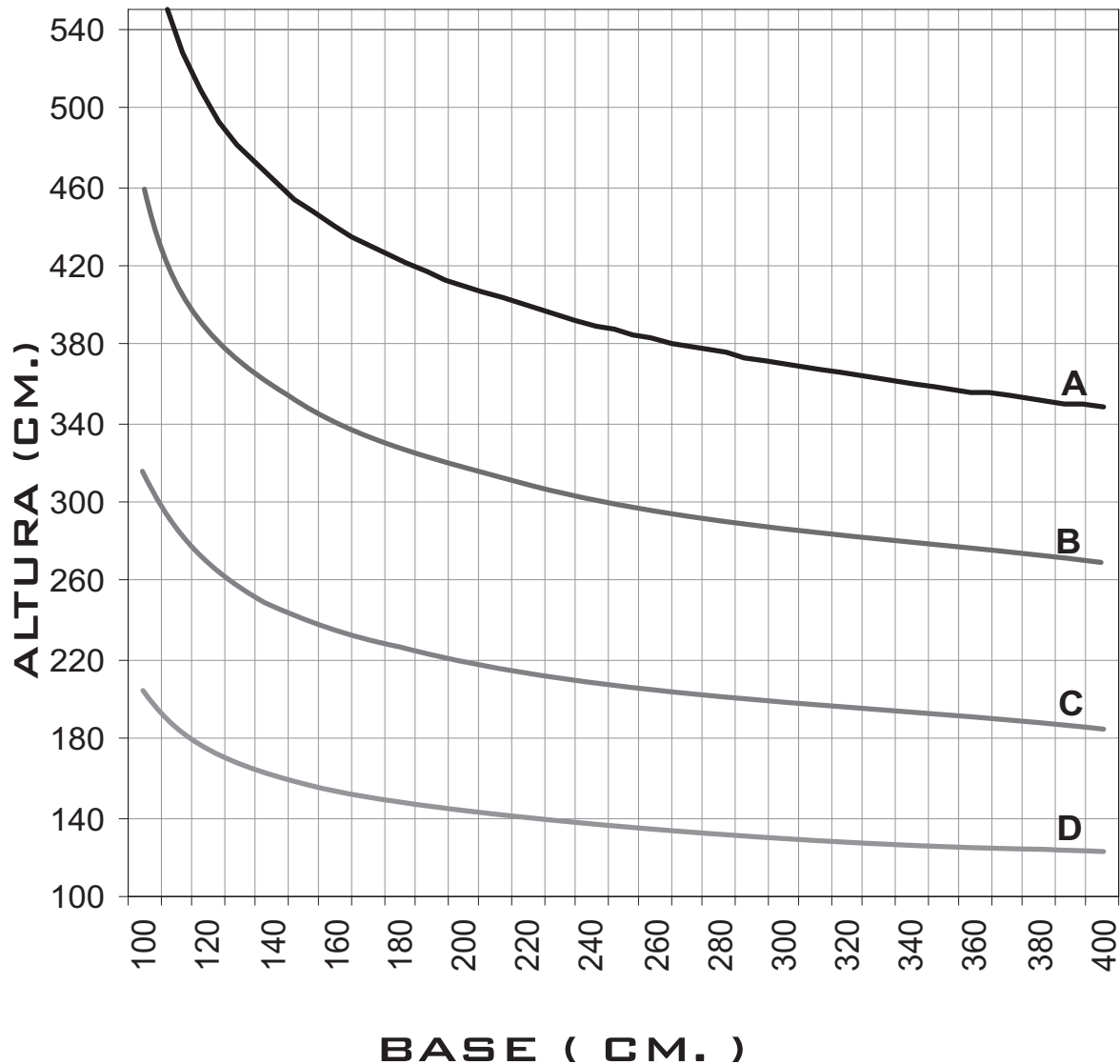

Calculo basado en un edificio de 15 Mts. de altura

A: Grandes Ciudades 92 Km/h    B: Zona Residencial 115 Km/h  
C: Campo Abierto 145 Km/h    D: Zona Costera 213 Km/h

La Resistencia al Viento esta basada en los Perfiles y Herrajes que componen la ventana o puerta.



# TIPOS DE APERTURAS

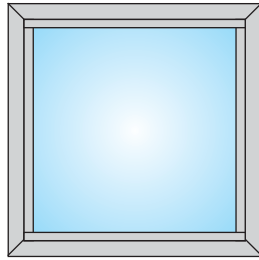

**FIJO**

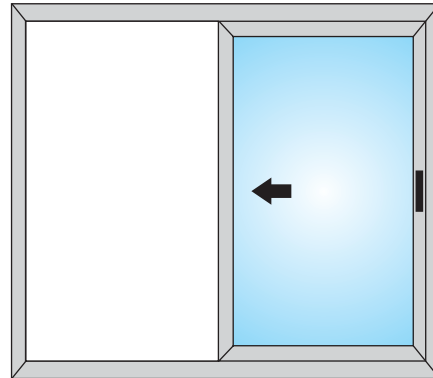

**CORREDERA MONORIEL**

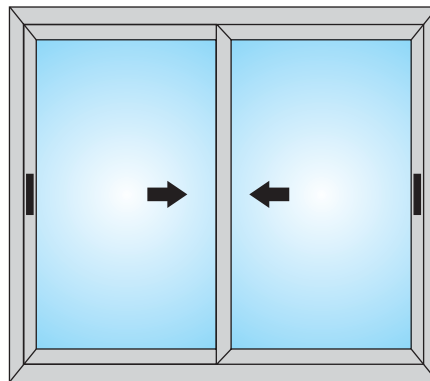

**CORREDERA 2 HOJAS**



# TIPOS DE APERTURAS

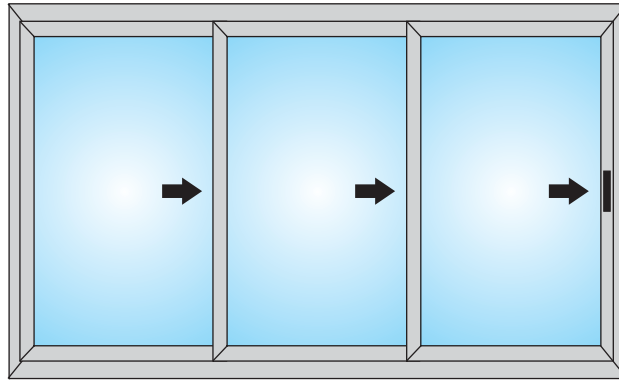

**CORREDERA 3 HOJAS**

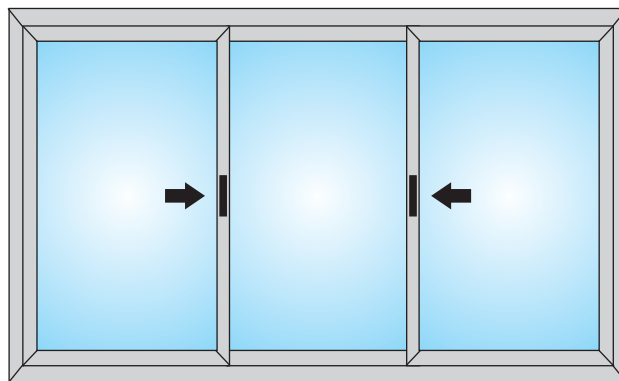

**CORREDERA 3 HOJAS**



# TIPOS DE APERTURAS

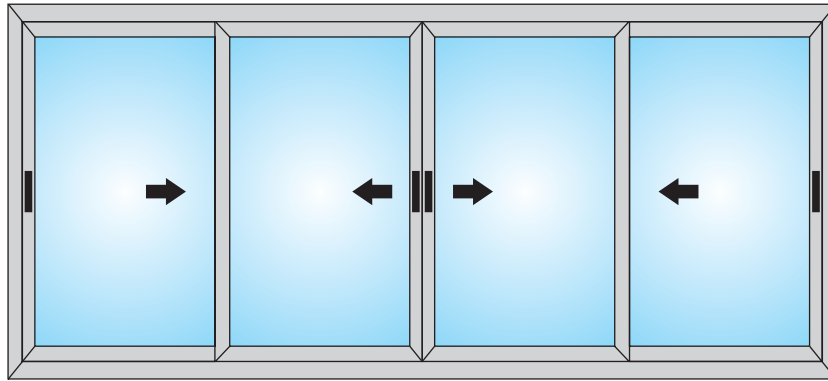

**CORREDERA 4 HOJAS**

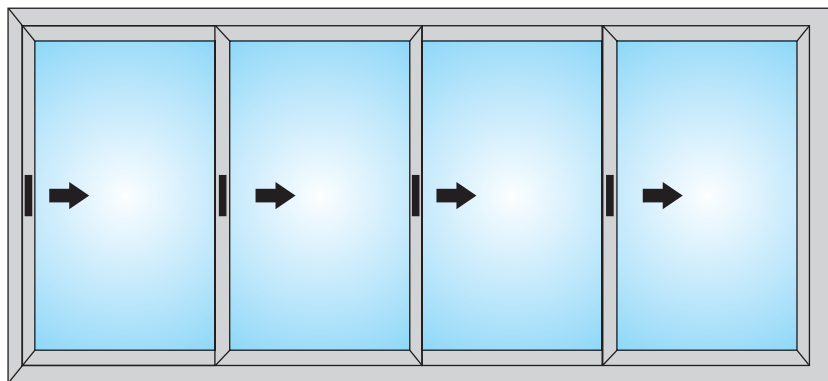

**CORREDERA 4 HOJAS**